

**MICROSTAGE™ SERIES**

Micro Positioning Stage System  
USM42

**USER'S MANUAL**

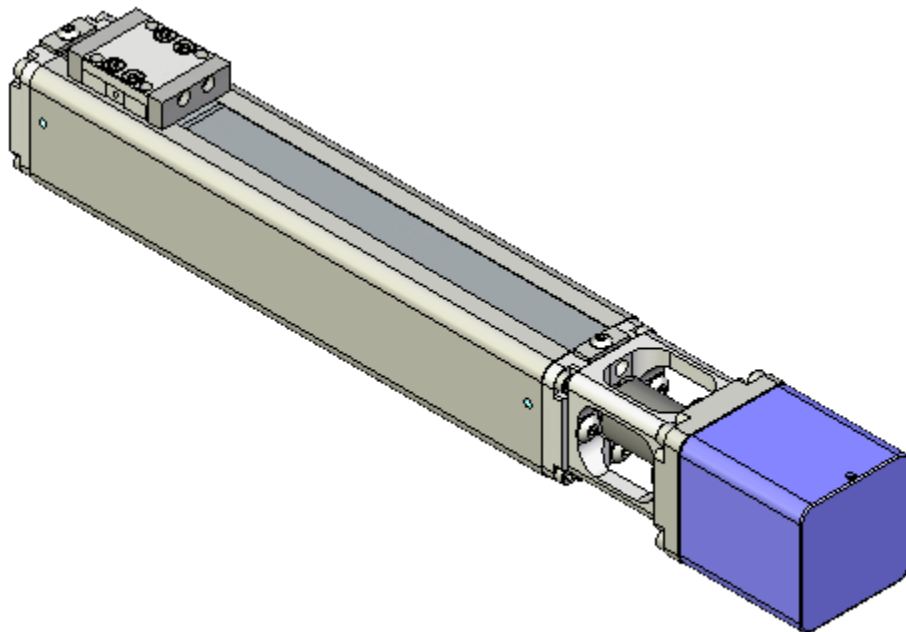

© 2010 USAutomation, Inc.  
All rights reserved

## **USAutomation<sup>®</sup> Microstage<sup>™</sup> Series User's Manual**

This manual, as well as the software described in it, is furnished under license and may be used or copied only in accordance with the terms of such license. The content of this manual is furnished for informational use only, is subject to change without notice and should not be construed as a commitment by USAutomation. USAutomation assumes no responsibility or liability for any errors or inaccuracies that may appear herein.

Except as permitted by such license, no part of this publication may be reproduced, stored in a retrieval system or transmitted, in any form or by any means, electronic, mechanical, recording, or otherwise, without the prior written permission of USAutomation.

USAutomation, Inc.  
23011 Moulton Parkway  
Suite J2  
Laguna Hills, CA 92653  
(949) 588-0513  
(949) 588-8761 fax  
[www.usautomation.com](http://www.usautomation.com)

## Revision Notes

1.0	Original release	
1.1	10/2/09	Updated limit switch sensor part number
1.2	5/26/10	Updated part number scheme
1.3	10/26/10	Added moment loading
1.4	11/9/11	Correct motor part number on page 7

## Contents

Revision Notes.....	3
Using This Manual .....	5
Product Returns.....	5
Unpacking and Handling.....	5
Assembly Diagram.....	6
Specifications.....	6
Dimensions .....	7
Moment Loading .....	8
Part Number Configuration.....	8
Mounting the USM42 .....	9
Mounting a Load to the USM42.....	9
Step Motor Information.....	9
Electrical Rating Information.....	9
Electrical Schematic .....	9
Switching Sequence .....	10
Limit Switch Information .....	10
Dimensions.....	10
Wiring.....	11

## Using This Manual

The Microstage Series are small packaged positioning stage systems which normally includes a step motor and coupling. The USM42 has a cross sectional size of 42mm x 42mm, travel lengths up to 400mm, an anti-backlash TFE coated leadscrew and a square rail supported carriage for mounting a load.

This manual provides the basic information necessary to unpack, set up, and configure the USM42. If additional information is required beyond what is presented here, please refer to the Support section of our website or contact USAutomation Applications Engineering.

## Product Returns

All returns for warranty or out-of-warranty repairs must first receive an RMA (Return Material Authorization) number. Please contact USAutomation Customer Service Department with information about the return and an RMA number will be issued if warranted.

Products returned to the factory will be examined and tested for failure mode and cause. USAutomation Customer Service will contact the customer with the repair cost if the required repair is out of warranty.

## Unpacking and Handling

Carefully remove the USM42 from its shipping box and inspect the unit for any evidence of shipping damage. Report any damage immediately to USAutomation. Please save the shipping box for damage inspection or its use in returning product if necessary.

Please observe the following guidelines for handling and mounting of your USM42:

- Do not drop the stage on any hard surface or subject it to any impact loads. Dropping the stage or other impact loads may result in bearing damage or misalignment.
- Do not drill holes into the stage. Drilling holes into the stage can generate particles and machining forces that may affect the operation of the stage. USAutomation can supply the USM42 with modifications to your drawing. Please contact the factory for a quote.
- Do not expose the USM42 to mist, spray or submersion in liquids.
- Do not disassemble the USM42. Unauthorized adjustments may alter the specifications and void the product warranty.

## Assembly Diagram

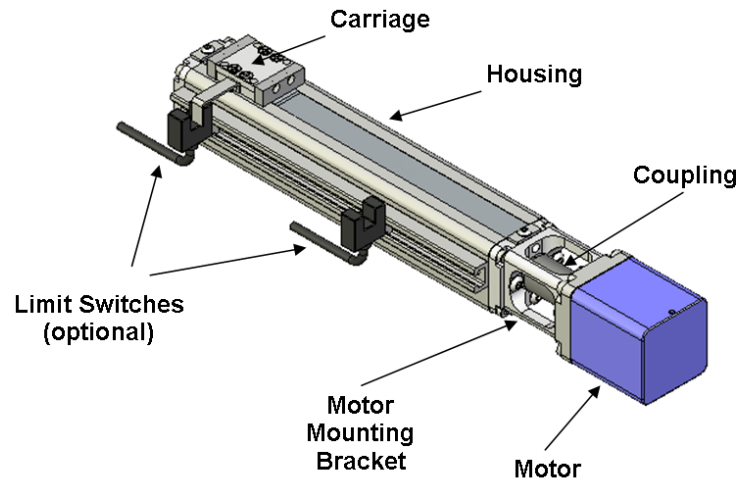

## Specifications

Part Number	Maximum Dynamic Load (lbs)	Travel (MM)	Lead (in)	Accuracy (in/in)	Max Linear Speed (in/sec)	Lead-screw Efficiency	Coeff of Friction (Constant)	Drag Torque (in/oz)	Motor Torque (oz in)
USM42T-040-XX-X	20	40	.100	.0008	4.5	49	.09	1-3	50
USM42T-080-XX-X	20	80	.100	.0008	4.5	49	.09	1-3	50
USM42T-120-XX-X	20	120	.100	.0008	4.5	49	.09	1-3	50
USM42T-160-XX-X	20	160	.100	.0008	4.5	49	.09	1-3	50
USM42T-200-XX-X	20	200	.100	.0008	4.5	49	.09	1-3	50
USM42T-240-XX-X	20	240	.100	.0008	4.5	49	.09	1-3	50
USM42T-280-XX-X	20	280	.100	.0008	4.5	49	.09	1-3	50
USM42T-320-XX-X	20	320	.100	.0008	4.5	49	.09	1-3	50
USM42T-360-XX-X	20	360	.100	.0008	4.5	49	.09	1-3	50
USM42T-400-XX-X	20	400	.100	.0008	4.5	49	.09	1-3	50

## Dimensions

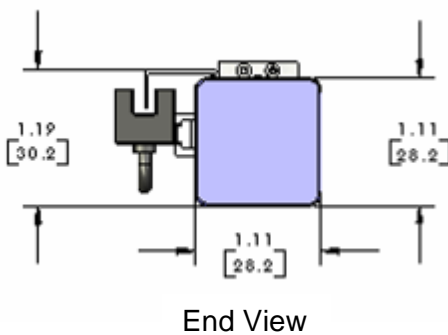
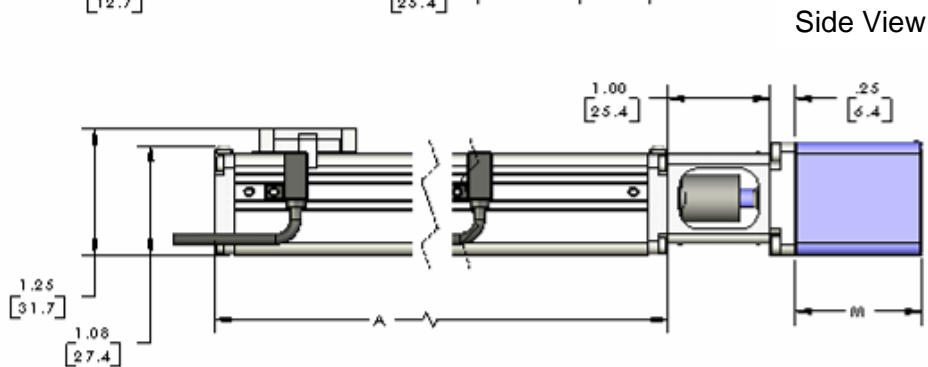
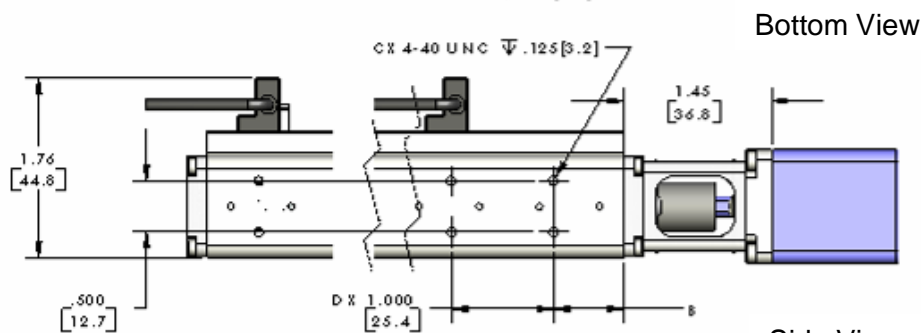
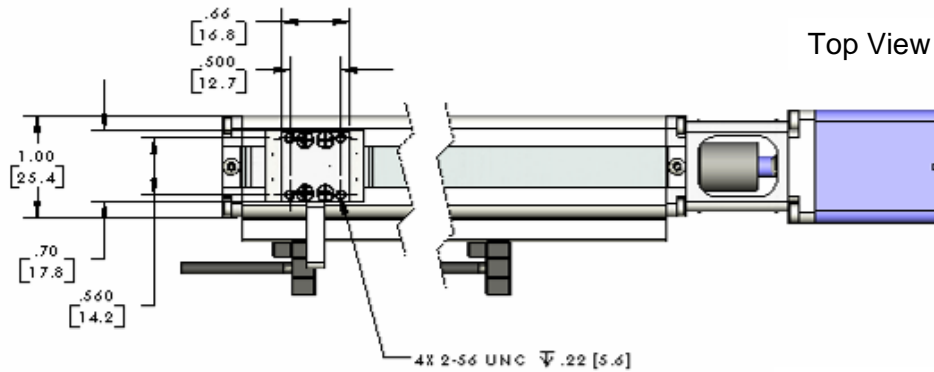

Motor	Dim M in (mm)
USS17T2102-4S	1.25 (31.8)
USS17T2202-4S	1.75 (44.5)
USS17T2302-4S	2.00 (50.8)

Travel in (mm)	Dim A in (mm)	Dim B in (mm)	Qty C	Qty D
0.39 (10)	2.05 (52)	.325 (8.3)	4	1
0.98 (25)	2.64 (67)	.687 (17.2)	4	1
1.57 (40)	3.23 (82)	.325 (8.3)	6	2
2.17 (55)	3.82 (97)	.687 (17.4)	6	2
2.76 (70)	4.41 (112)	.325 (8.3)	8	3
3.35 (85)	5.00 (127)	.325 (8.3)	10	4
3.94 (100)	5.59 (142)	.687 (17.4)	10	4
4.53 (115)	6.18 (157)	.325 (8.3)	12	5
5.12 (130)	6.77 (172)	.687 (17.4)	12	5
5.71 (145)	7.36 (187)	.325 (8.3)	14	6
6.30 (160)	7.96 (202)	.687 (17.4)	14	6
6.89 (175)	8.55 (217)	.325 (8.3)	16	7
7.48 (190)	9.14 (232)	.325 (8.3)	18	8
8.07 (205)	9.73 (247)	.687 (17.4)	18	8

## Moment Loading

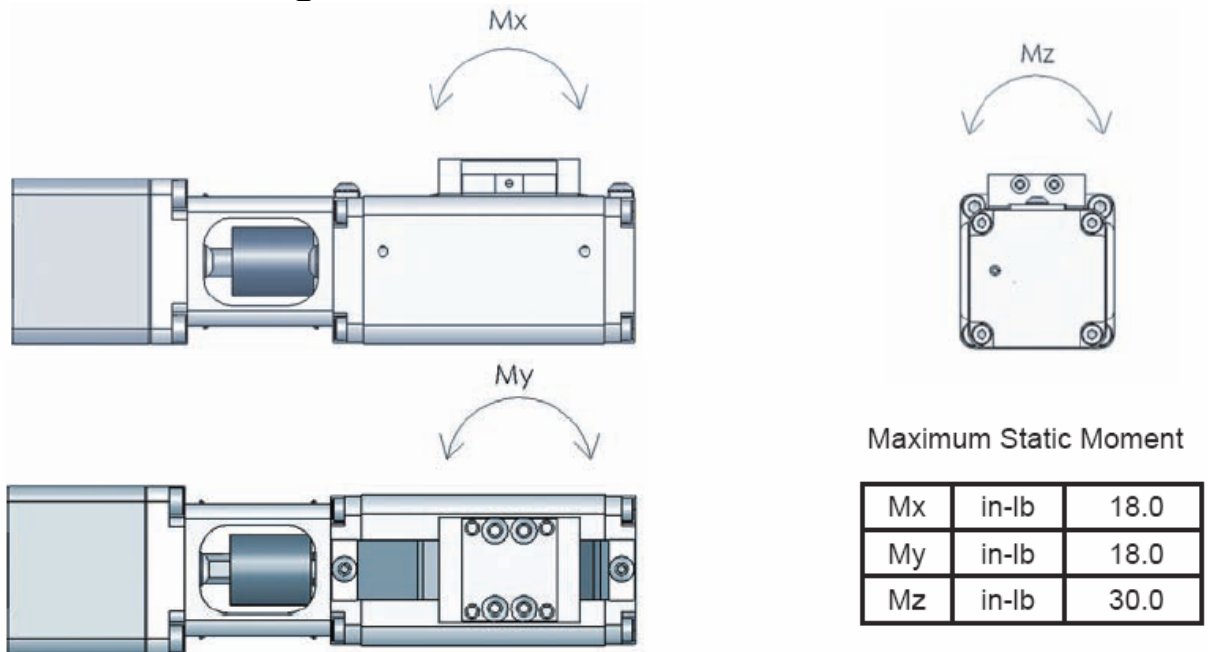

## Part Number Configuration

The part number for the Microstage USM28 is determined as follows:

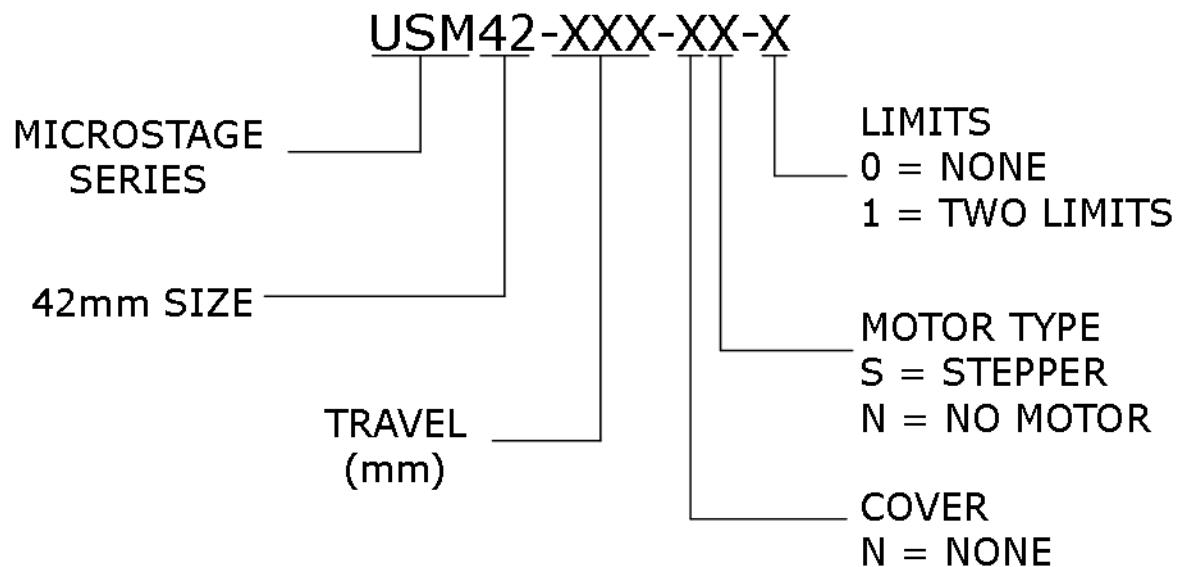



## Mounting the USM42

Threaded mounting holes are located on the underside of the housing. The holes for the USM42 are M3 x .5 with a .188" depth. Generally it is best to have through holes matching the pattern of the mounting holes in the surface to which it is to be secured such that M3 screws pass through the surface and into the threads in the housing. Review page 7 of this manual for the location and number of holes based on the length of the Microstage. Care should be taken to not let the mounting screws penetrate the carriage more than the .188" depth or there may be interference with moving components in the stage.

## Mounting a Load to the USM42

Motor	Bipolar Torque (oz in)	Series Current (A)	Series Inductance (mH)	Rotor Inertia (oz in sec <sup>2</sup> )	Shaft Diameter (in)	# of Leads	Weight (lbs)	Length (in)
USS17T2202-4S	50	0.85	10.0	.00076	.197	4	.60	1.575

Four (4) 6-32 UNC with .375" depth are located on the top of the carriage for mounting a load to the USM42 (See the Dimensions section). Care should be taken not to exceed this maximum depth so as to not interfere with other components of the carriage assembly.

## Step Motor Information

The standard motor which comes with the USM42 is a 1.8° hybrid step motor with four leads. This motor can be connected to any bipolar step motor driver/controller. Full torque will be available from the motor when used with a drive which has a rated output with at least .85 amps per phase. Here are the ratings for the standard Microstage USM42 step motor:

### *Electrical Rating Information*

Other motors are available from USAutomation including longer stack length step motors, motors with built in drive/controllers, and brushless motors. Please contact the factory for more information.

### *Electrical Schematic*

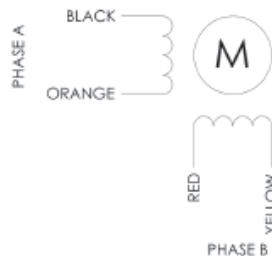

Switching Sequence

	Black	Orange	Red	Yellow
Step 1	+	-	+	-
Step 2	-	+	+	-
Step 3	-	+	-	+
Step 4	+	-	-	+

Limit Switch Information

If your Microstage has the optional limit switches they will be mounted on the side of the stage housing and are adjustable. Depending on the driver used the limit switches can be configured as end-of-travel limits and/or one of them can be configured as a home switch.

The limit switches provided are SUNX model PM-F24, an infrared U-channel switch which is interrupted by a flag mounted to the moving carriage of the Microstage. The output of the switches is NPN open-collector with both Light-ON and Dark-ON modes. A 1.0 meter cable is supplied to make the connections to the driver.

Dimensions

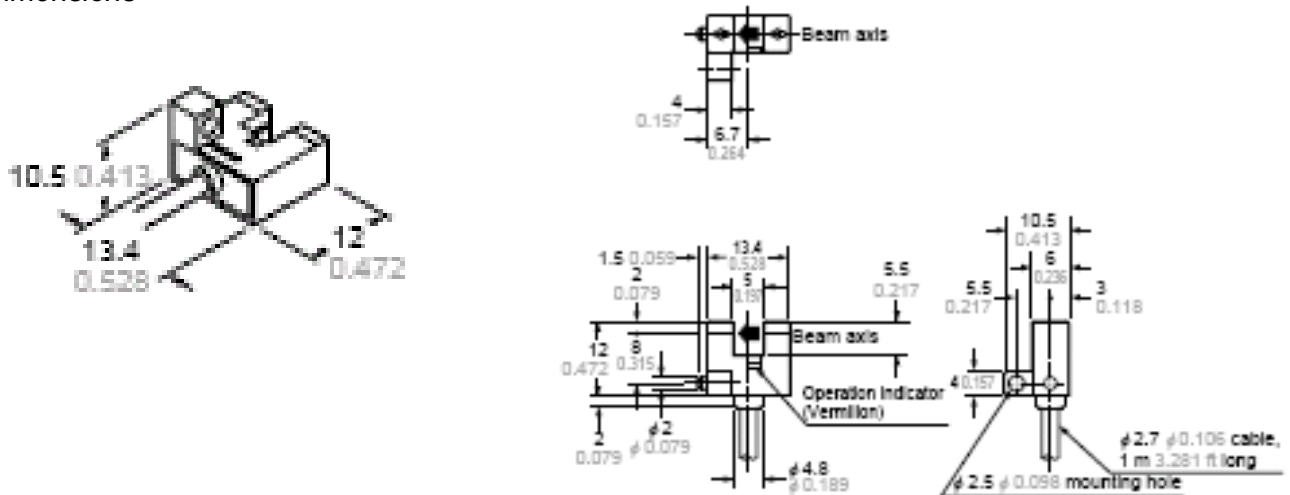

Wiring

Wiring diagram

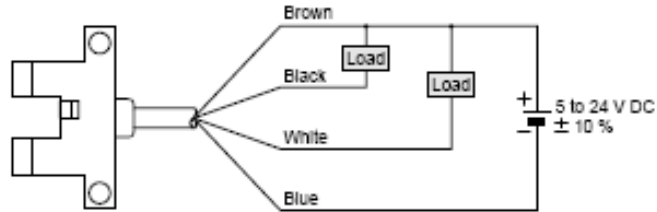

Output operation

	Color code	Output operation
Output 1	Black	Light-ON
Output 2	White	Dark-ON

Generally, Output 2 will be used because the switch output will then go ON when the flag interrupts the switch. In addition, for safety the switch will appear triggered (shutting down travel) if there is a break in the wiring to the switch.

If further more detailed information is required for the sensor, please refer to this URL: <http://www.sunx-ramco.com/SunxPDFFiles/PM.pdf> .