

8 7 6 5 4 3 2 1

D  
C  
B  
A

D  
C  
B  
A

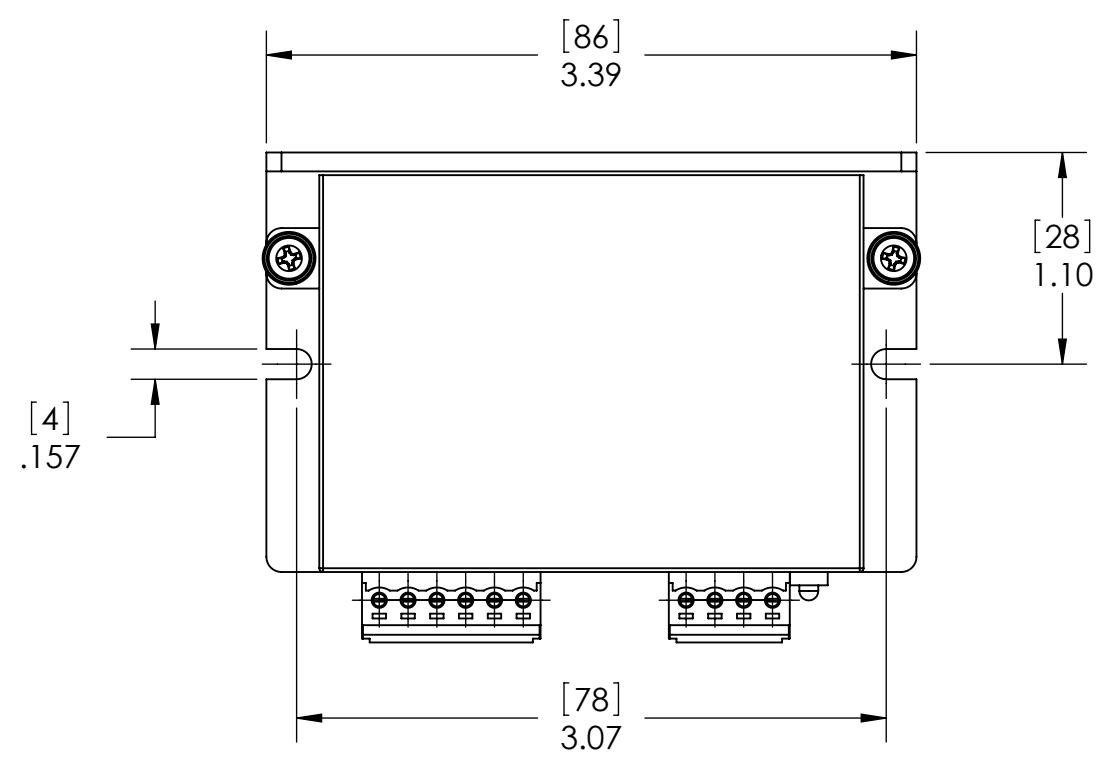
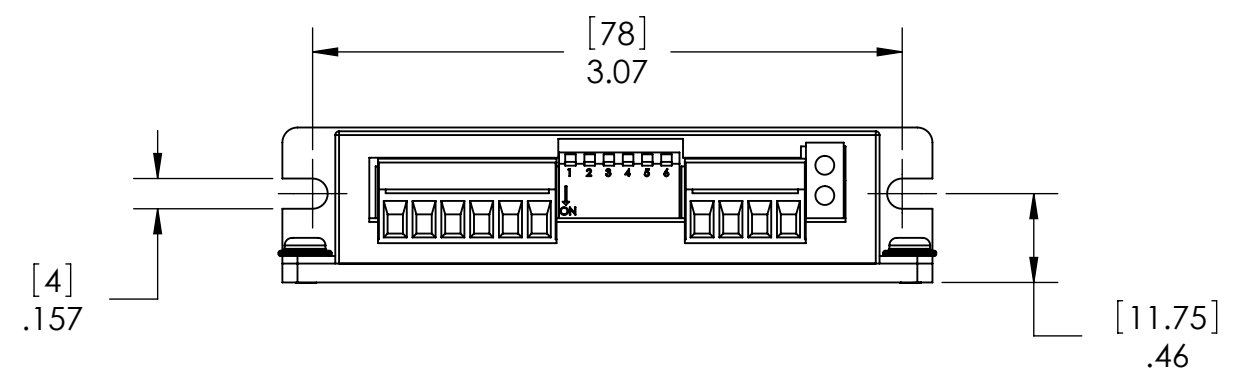
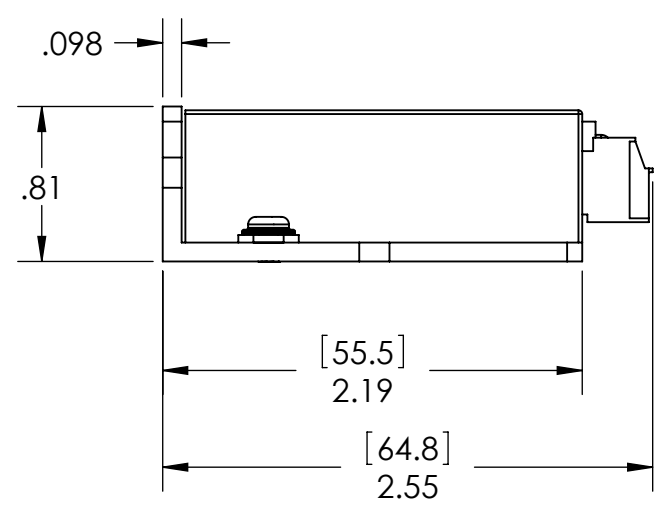

**PROPRIETARY AND CONFIDENTIAL**  
 THE INFORMATION CONTAINED IN THIS DRAWING IS THE SOLE PROPERTY OF USAUTOMATION ANY REPRODUCTION IN PART OR AS A WHOLE WITHOUT THE WRITTEN PERMISSION OF USAUTOMATION IS PROHIBITED.

		UNLESS OTHERWISE SPECIFIED:	NAME	DATE
		DIMENSIONS ARE IN INCHES	DRAWN	
		TOLERANCES:	CHECKED	
		FRACTIONAL $\pm 1/32$	ENG APPR.	
		ANGULAR: MACH $\pm .5^\circ$ BEND $\pm 1^\circ$	MFG APPR.	
		TWO PLACE DECIMAL $\pm .03$	Q.A.	
		THREE PLACE DECIMAL $\pm .005$	COMMENTS:	
		INTERPRET GEOMETRIC TOLERANCING PER:		
		MATERIAL		
NEXT ASSY	USED ON	FINISH		
APPLICATION		DO NOT SCALE DRAWING		



23011 MOULTON PARKWAY, SUITE J2  
 LAGUNA HILLS, CA 92653  
 PH: 949-588-0513 FAX: 949-588-8761

TITLE: **USSD2240**

SIZE <b>B</b>	DWG. NO.	REV
---------------	----------	-----

SCALE: 1:1    WEIGHT:    SHEET 1 OF 1

8 7 6 5 4 3 2 1